

# AC charging cable - EV-T2G3C-3AC32A-15,0M6,0ESBK01

1047633

<https://www.phoenixcontact.com/gb/products/1047633>

Please be informed that the data shown in this PDF document is generated from our Online Catalog. Please find the complete data in the user documentation. Our General Terms of Use for Downloads are valid.



CHARX connect, AC charging cable with vehicle charging connector and open cable end, with protective cap, Housing color black-gray, for charging electric vehicles (EV) with alternating current (AC) via type 2 vehicle charging inlets, for installation at charging stations for electromobility (EVSE), Type 2, IEC 62196-2, 32 A / 480 V (AC), C-Line, "PHOENIX CONTACT" logo, cable: 15 m, black, straight, NOTE: Signal transmission is dependent on the cable length and may be adversely affected.

## Product Description

AC charging cable with Vehicle Connector and open cable end for charging electric vehicles (EV) with alternating current (AC) via type 2 Vehicle Inlets, for installation at charging stations for E-Mobility (EVSE)

## Your advantages

- Complete product range
- Convenient handling due to the ergonomic, triple award-winning design
- Available with your logo on request – for consistent branding of your charging station
- Longitudinal water tightness reliably prevents water ingress
- Developed and produced in accordance with the IATF 16949 automotive standard and ISO 9001
- Tested in accordance with automotive standards LV124, LV214, and LV215-2
- Tested in accordance with EV Ready 37 requirements
- Laser-marked mating face in accordance with DIN EN 17186

# AC charging cable - EV-T2G3C-3AC32A- 15,0M6,0ESBK01



1047633

<https://www.phoenixcontact.com/gb/products/1047633>

## Commercial Data

Item number	1047633
Packing unit	1 pc
Minimum order quantity	1 pc
Sales Key	XWBAAC
Product Key	XWBAAC
GTIN	4055626648927
Weight per Piece (including packing)	7,525 g
Weight per Piece (excluding packing)	7,525 g
Customs tariff number	85444290
Country of origin	PL

# AC charging cable - EV-T2G3C-3AC32A- 15,0M6,0ESBK01



1047633

<https://www.phoenixcontact.com/gb/products/1047633>

## Technical Data

### Product properties

Product type	AC charging cable
Application	for charging electric vehicles (EV) with alternating current (AC) via type 2 vehicle charging inlets for installation at charging stations for electromobility (EVSE)
Type	AC charging cable with vehicle charging connector and open cable end with protective cap Housing color black-gray
Affixed logo	"PHOENIX CONTACT" logo
Charging mode	Mode 3, Case C
Charging standard	Type 2

### Electrical properties

Number of phases	3
Type of signal transmission	Pulse width modulation
Type of charging current	AC 3-phase
Note on the connection method	Crimp connection, cannot be disconnected
Coding	220 Ω (between PE and PP)
Maximum capacity	26.6 kW

### Power contact

Number	5 (L1, L2, L3, N, PE)
Rated voltage	480 V AC
Rated current	32 A

### Signal contact

Number	2 (CP, PP)
Rated voltage	30 V AC
Rated current	2 A

### Dimensions

Dimensional drawing	
Width	70 mm (Vehicle charging connector)
Height	137 mm (Vehicle charging connector)
Depth	215.9 mm (Vehicle charging connector)

### Material specifications

# AC charging cable - EV-T2G3C-3AC32A-15,0M6,0ESBK01



1047633

<https://www.phoenixcontact.com/gb/products/1047633>

Housing material	Plastic
Material of grip body	Soft plastic
Material protective cap	Soft plastic
Material mating face	Plastic
Material surface of contacts	Ag

## Design

Color Housing	black
Color Connection profile	black
Color Handle area	gray
Color Protective cap	black
Customer variations	On request

## Cable / line

Cable length	15 m
Wiring standards/regulations	prEN 50620 / DIN EN 50620
Wiring certifications	VDE
Cable weight	max. 505 kg/km
Type of cable	straight
Cable structure	5 x 6.0 mm <sup>2</sup> + 1 x 0.5 mm <sup>2</sup>
Cable type	Class 5
External cable diameter	17 mm ±0.4 mm
Outer sheath, material	TPE-U
External sheath, color	black
Conductor resistance	≤ 0.0033 Ω/m (based on a power core, at an ambient temperature of 20°C)

## Cable structure

Stripping length of the sheath	70 mm ±5 mm
--------------------------------	-------------

## Mechanical properties

### Design

Design	C-Line
--------	--------

### Mechanical data

Insertion force	< 100 N
Withdrawal force	< 100 N

### Design

Design	C-Line
Customer variations	On request

## Environmental and real-life conditions

### Ambient conditions

Ambient temperature (operation)	-30 °C ... 50 °C
---------------------------------	------------------

# AC charging cable - EV-T2G3C-3AC32A-15,0M6,0ESBK01



1047633

<https://www.phoenixcontact.com/gb/products/1047633>

Ambient temperature (storage/transport)	-40 °C ... 80 °C
Altitude	5000 m (above sea level)

## Standards and regulations

### Connection in accordance with standard

Normative cable length restrictions	NOTE: Signal transmission is dependent on the cable length and may be adversely affected.
	The cable capacity must therefore be assessed in the overall system of the charging station and must not exceed 3100 pF (IEC 61851-1, Annex A, Table A.2, Note d).
	Interference-free V2G communication in accordance with ISO 15118 is not guaranteed for cable lengths over 10 m (ISO IEC 15118-3, A.11.3, Table A.11).
	Cable management is required in certain regions if the cable length exceeds 5.0 m (Switzerland) or 7.5 m (USA) (IEC 61851-1).

### Standards

Standards/regulations	IEC 62196-2
-----------------------	-------------

# AC charging cable - EV-T2G3C-3AC32A- 15,0M6,0ESBK01

1047633

<https://www.phoenixcontact.com/gb/products/1047633>

## Drawings

Schematic diagram

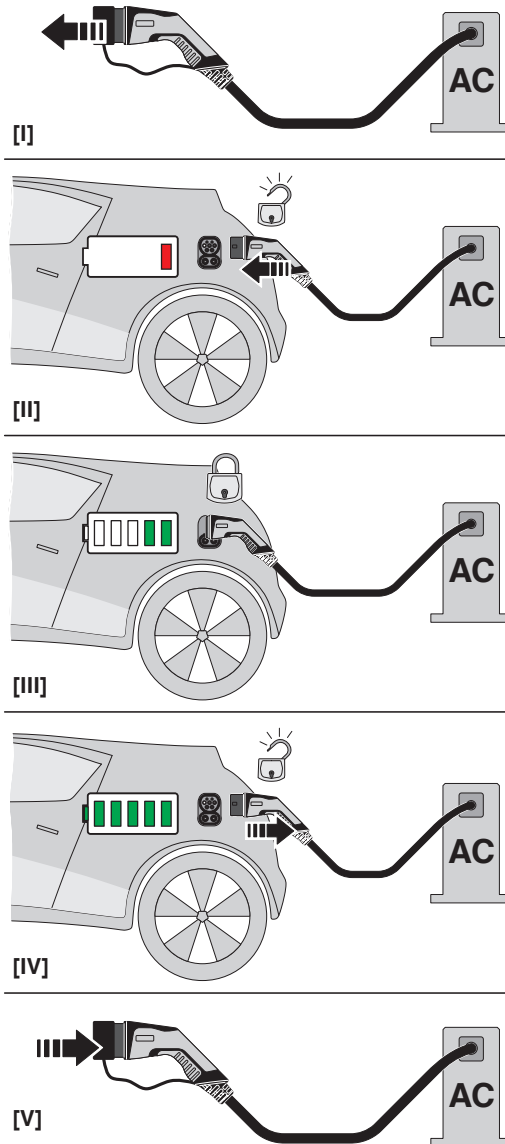

Operating instructions

# AC charging cable - EV-T2G3C-3AC32A-15,0M6,0ESBK01



1047633

<https://www.phoenixcontact.com/gb/products/1047633>

Dimensional drawing

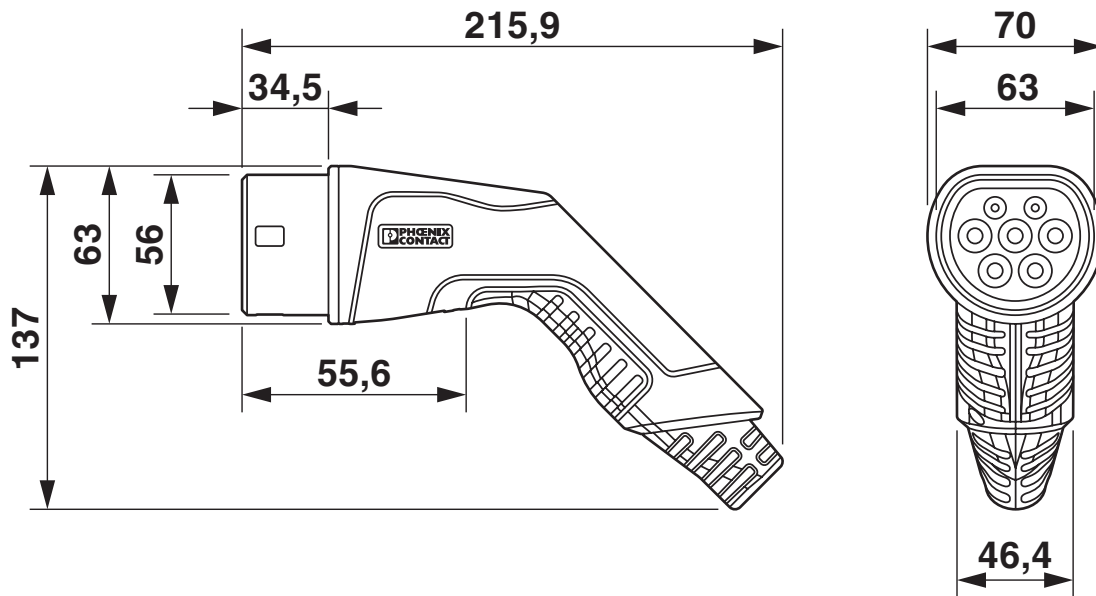

Make sure that the vehicle charging connector is placed in an appropriate charging connector holder, which ensures a minimum protection rating of IP24 in accordance with IEC 61851-1, for the entire time between charging. To create this charging connector holder, use the dimensions of the vehicle charging connector. Detailed dimensions can also be found in the Download area.

Schematic diagram

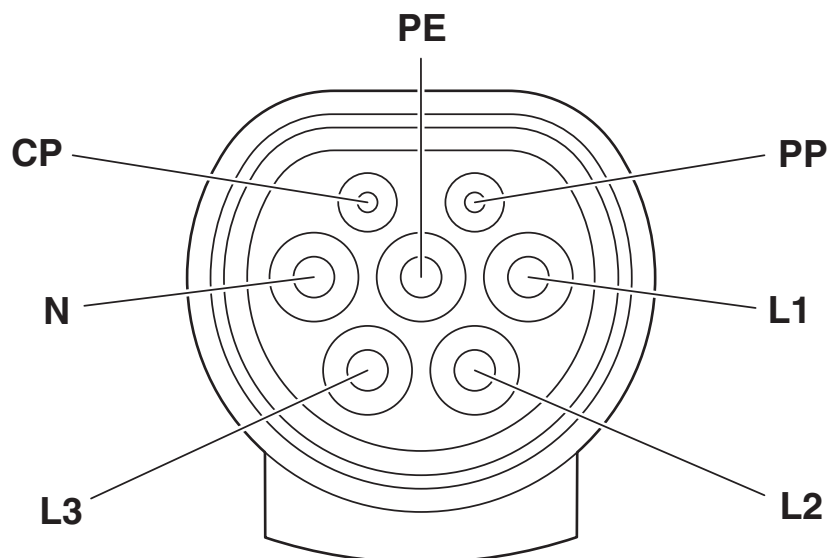

Pin assignment of the Vehicle Connector

# AC charging cable - EV-T2G3C-3AC32A-15,0M6,0ESBK01

1047633

<https://www.phoenixcontact.com/gb/products/1047633>

Schematic diagram

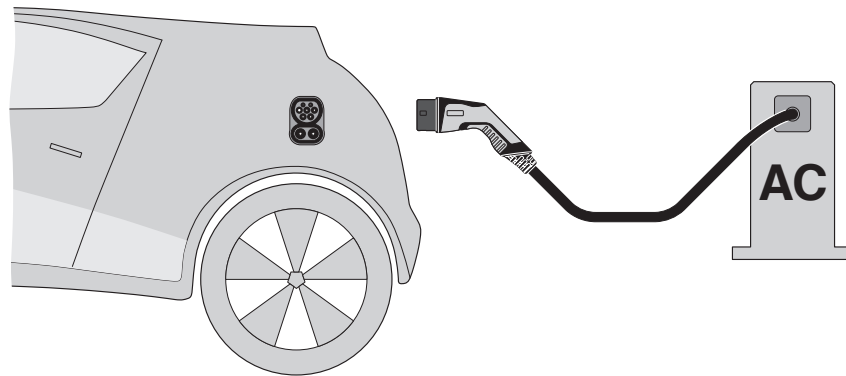

Terminology definition



# AC charging cable - EV-T2G3C-3AC32A- 15,0M6,0ESBK01



1047633

<https://www.phoenixcontact.com/gb/products/1047633>

## Approvals

 <b>IECEE CB Scheme</b> Approval ID: DE1-61066/M1	Nominal Voltage $U_N$	Nominal Current $I_N$	Cross Section AWG	Cross Section $\text{mm}^2$
	480 V	32 A	-	-

 <b>VDE Zeichengenehmigung</b> Approval ID: 40045387	Nominal Voltage $U_N$	Nominal Current $I_N$	Cross Section AWG	Cross Section $\text{mm}^2$
	480 V	32 A	-	-

# AC charging cable - EV-T2G3C-3AC32A-15,0M6,0ESBK01



1047633

<https://www.phoenixcontact.com/gb/products/1047633>

## Classifications

### ECLASS

ECLASS-9.0	27144705
ECLASS-10.0.1	27144705
ECLASS-11.0	27144705

### ETIM

ETIM 8.0	EC002897
----------	----------

### UNSPSC

UNSPSC 21.0	39121522
-------------	----------

# AC charging cable - EV-T2G3C-3AC32A-15,0M6,0ESBK01



1047633

<https://www.phoenixcontact.com/gb/products/1047633>

## Environmental Product Compliance

REACH SVHC	Lead 7439-92-1
China RoHS	Environmentally Friendly Use Period = 10; For details about hazardous substances go to tab "Downloads", Category "Manufacturer's declaration"

# AC charging cable - EV-T2G3C-3AC32A- 15,0M6,0ESBK01



1047633

<https://www.phoenixcontact.com/gb/products/1047633>

## Accessories

### Measuring instrument

Measuring instrument - EEM-EM357 - 2908588

<https://www.phoenixcontact.com/gb/products/2908588>

Three-phase power meter for active power measurement with direct measurement in networks of up to 500 V / 80 A, with S0 output, with digital input and RS-485 interface, certified in accordance with the MID directive



---

### Cable gland

Cable gland - G-INS-M32-M68N-PNES-BK - 1411136

<https://www.phoenixcontact.com/gb/products/1411136>

Cable gland, cable gland material: PA, external cable diameter 15 mm ... 21 mm, shielding: no, connecting thread: M32 x 1.5, color: jet black RAL 9005



# AC charging cable - EV-T2G3C-3AC32A- 15,0M6,0ESBK01

1047633

<https://www.phoenixcontact.com/gb/products/1047633>

## Type 2 surge arrester

Type 2 surge arrester - VAL-EV-T2 280/3+1 - 1180144

<https://www.phoenixcontact.com/gb/products/1180144>



CHARX protect: pluggable surge protective device, in accordance with Type 2 / Class II, for 3-phase power supply networks with separate N and PE (5-conductor system: L1, L2, L3, N, PE). Specifically designed for use in e-mobility.

---

## Type 2 surge arrester

Type 2 surge arrester - VAL-EV-T2 280/3+1-R - 1180145

<https://www.phoenixcontact.com/gb/products/1180145>



CHARX protect: pluggable surge protective device, in accordance with Type 2 / Class II, for 3-phase power supply networks with separate N and PE (5-conductor system: L1, L2, L3, N, PE), with remote indication contact. Specifically designed for use in e-mobility.

# AC charging cable - EV-T2G3C-3AC32A-15,0M6,0ESBK01

1047633

<https://www.phoenixcontact.com/gb/products/1047633>

## AC charging controller

AC charging controller - CHARX SEC-1000 - 1139034

<https://www.phoenixcontact.com/gb/products/1139034>



CHARX control modular, AC charging controller according to IEC 61851-1. Standard. operating mode Stand-alone or client. interface: CHARX control modular system bus. Connectable peripheral devices: Energy meter, RFID, DC residual current detection. DIN rail mounting

---

## AC charging controller

AC charging controller - CHARX SEC-3000 - 1139022

<https://www.phoenixcontact.com/gb/products/1139022>



CHARX control modular, AC charging controller according to IEC 61851-1. Embedded Linux system. operating mode Stand-alone, server, or client. interface: Ethernet (2x), CHARX control modular system bus, MICRO-USB type C. communication protocol: OCPP 1.6J, Modbus/TCP, MQTT. Connectable peripheral devices: Energy meter, RFID, DC residual current detection. DIN rail mounting

# AC charging cable - EV-T2G3C-3AC32A-15,0M6,0ESBK01

1047633

<https://www.phoenixcontact.com/gb/products/1047633>

## AC charging controller

AC charging controller - CHARX SEC-3050 - 1139018

<https://www.phoenixcontact.com/gb/products/1139018>



CHARX control modular, AC charging controller according to IEC 61851-1, ISO/IEC 15118. Embedded Linux system. operating mode Stand-alone, server, or client. interface: Ethernet (2x), CHARX control modular system bus, MICRO-USB type C. communication protocol: OCPP 1.6J, Modbus/TCP, MQTT. Connectable peripheral devices: Energy meter, RFID, DC residual current detection. DIN rail mounting

---

## AC charging controller

AC charging controller - CHARX SEC-3100 - 1139012

<https://www.phoenixcontact.com/gb/products/1139012>



CHARX control modular, AC charging controller according to IEC 61851-1. Embedded Linux system. operating mode Stand-alone, server, or client. interface: Ethernet (2x), Cellular communication (4G/2G), CHARX control modular system bus, MICRO-USB type C. communication protocol: OCPP 1.6J, Modbus/TCP, MQTT. Connectable peripheral devices: Energy meter, RFID, DC residual current detection. DIN rail mounting

# AC charging cable - EV-T2G3C-3AC32A-15,0M6,0ESBK01

1047633

<https://www.phoenixcontact.com/gb/products/1047633>

## AC charging controller

AC charging controller - CHARX SEC-3150 - 1138965

<https://www.phoenixcontact.com/gb/products/1138965>



CHARX control modular, AC charging controller according to IEC 61851-1, ISO/IEC 15118. Embedded Linux system. operating mode Stand-alone, server, or client. interface: Ethernet (2x), Cellular communication (4G/2G), CHARX control modular system bus, MICRO-USB type C. communication protocol: OCPP 1.6J, Modbus/TCP, MQTT. Connectable peripheral devices: Energy meter, RFID, DC residual current detection. DIN rail mounting

---

## AC charging controller

AC charging controller - EV-CC-AC1-M3-CC-SER-HS - 1622459

<https://www.phoenixcontact.com/gb/products/1622459>



The EV-CC-AC1-M3-CBC-SER-HS charging controller with housing for DIN rail mounting is used for charging electric vehicles at 3-phase AC networks according to IEC 61851-1, Mode 3. Optimized for charging stations with permanently mounted Vehicle Connector. All charging functions and comprehensive configuration settings are already integrated.



# AC charging cable - EV-T2G3C-3AC32A-15,0M6,0ESBK01

1047633

<https://www.phoenixcontact.com/gb/products/1047633>

## AC charging controller

AC charging controller - EV-CC-AC1-M3-CC-SER-PCB - 1622460

<https://www.phoenixcontact.com/gb/products/1622460>



The EV-CC-AC1-M3-CC-SER-PCB charging controller as a PCB for charging electric vehicles on a 3-phase AC power grid according to IEC 61851-1, Mode 3. Optimized for charging stations with permanently mounted Vehicle Connector. All charging functions and comprehensive configuration settings are already integrated.

---

## AC charging controller

AC charging controller - EV-CC-AC1-M3-CC-SER-PCB-XC-25X - 1627742

<https://www.phoenixcontact.com/gb/products/1627742>



The EV-CC-AC1-M3-CC-SER-PCB charging controller as a PCB for charging electric vehicles on a 3-phase AC power grid according to IEC 61851-1, Mode 3. Optimized for charging stations with permanently mounted Vehicle Connector. All charging functions and comprehensive configuration settings are already integrated.

# AC charging cable - EV-T2G3C-3AC32A-15,0M6,0ESBK01

1047633

<https://www.phoenixcontact.com/gb/products/1047633>

## AC charging controller

AC charging controller - EV-CC-AC1-M3-CC-SER-PCB-MSTB - 1627367

<https://www.phoenixcontact.com/gb/products/1627367>



The EV-CC-AC1-M3-CC-SER-PCB-MSTB charging controller as a PCB for charging electric vehicles according to IEC 61851-1, Mode 3, optimized for charging stations with permanently mounted Vehicle Connector. Connection via PCB connector on header.

---

## AC charging controller

AC charging controller - EM-CP-PP-ETH - 2902802

<https://www.phoenixcontact.com/gb/products/2902802>



EV charge control is used to charge electrical vehicles on the 3-phase AC mains power supply according to IEC 61851-1 Mode 3. All necessary control functions are integrated. Additional functions are available for various charging applications.

# AC charging cable - EV-T2G3C-3AC32A- 15,0M6,0ESBK01

1047633

<https://www.phoenixcontact.com/gb/products/1047633>

## Label

Label - EV-LABEL-C - 1309766

<https://www.phoenixcontact.com/gb/products/1309766>

CHARX connect, Label, accordance to DIN EN 17186, for AC charging cable, DIN EN 17186, Marking C for AC type 2 vehicle charging connectors and type 2 vehicle charging inlets



---

## Lightning/surge arrester type 1/2

Lightning/surge arrester type 1/2 - VAL-EV-T1/T2 264/12.5/3+1 - 1180149

<https://www.phoenixcontact.com/gb/products/1180149>

CHARX protect: pluggable lightning current arrester/surge protective device, in accordance with Type 1/2 / Class I/II, for 3-phase power supply networks with separate N and PE (5-conductor system: L1, L2, L3, N, PE). Specifically designed for use in e-mobility.



# AC charging cable - EV-T2G3C-3AC32A-15,0M6,0ESBK01

1047633

<https://www.phoenixcontact.com/gb/products/1047633>

## Lightning/surge arrester type 1/2

Lightning/surge arrester type 1/2 - VAL-EV-T1/T2 264/12.5/3+1-R - 1180150

<https://www.phoenixcontact.com/gb/products/1180150>



CHARX protect: pluggable lightning current arrester/surge protective device, in accordance with Type 1/2 / Class I/II, for 3-phase power supply networks with separate N and PE (5-conductor system: L1, L2, L3, N, PE), with remote indication contact. Specifically designed for use in e-mobility.

---

## Charging connector holder

Charging connector holder - EV-T2AC-PARK - 1624148

<https://www.phoenixcontact.com/gb/products/1624148>



CHARX connect, Charging connector holder, for vehicle charging connectors on charging stations (EVSE), Type 2, IEC 62196-2, Front mounting

---

Phoenix Contact 2022 © - all rights reserved

<https://www.phoenixcontact.com>

PHOENIX CONTACT Ltd  
Halesfield 13, Telford  
Shropshire, TF7 4PG  
01952 681700  
[info@phoenixcontact.co.uk](mailto:info@phoenixcontact.co.uk)